



SP6887

4 CHANNEL REGULATED CHARGE PUMP WLED DRIVER

FEATURES

- Peak Efficiency: 90%
- Individual Current Regulation
- 3-bit Digital Output Control
- 1x and 1.5x Modes of Operation
- Current Matching with a Max Tolerance of 3%
- Output Current up to 30mA per LED
- Fixed Frequency of 1MHz
- Open LED Protection
- Pb-Free Thin QFN-16 3mmx3mm Package

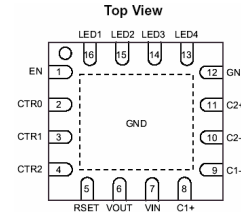

APPLICATIONS

- Cellular Phones
- LED backlighting
- LCD Modules
- Handheld Devices
- Digital Cameras
- PDAs
- MP3 Players



DESCRIPTION

The SP6887 is a 4-channel charge pump white LED driver, capable of driving up to 4 LEDs connected in parallel. The device operates in either 1x mode or 1.5x fractional mode, and it can switch from 1x mode to 1.5x mode automatically when the input voltage decreases. Its internal 4 current sink regulators ensure both LED current matching and brightness uniformity. The LED current can be programmed by an external resistor, R_{SET} , connected between the RSET pin and ground. LED currents of up to 30mA are supported by the input supply voltage over a range of 2.7V to 5.5V, making the device optimized for Li-Ion battery applications. The SP6887 has a fixed switching frequency of 1MHz, allowing the use of very small value ceramic capacitors. The enable input pin allows the device to be placed in shutdown mode while reducing current consumption to less than 1 μ A. LED dimming can be done by several methods including using a DC voltage to set the RSET pin current, adding a switched resistor in parallel with RSET or applying a PWM signal to CTRx pin or EN pin.

TYPICAL APPLICATION CIRCUIT

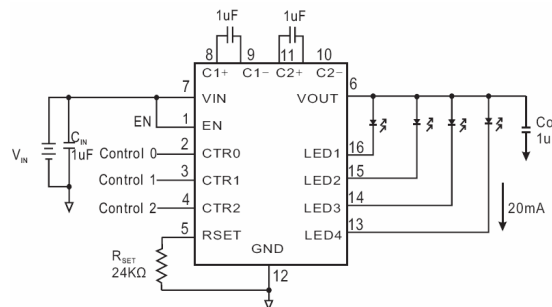

BLOCK DIAGRAM

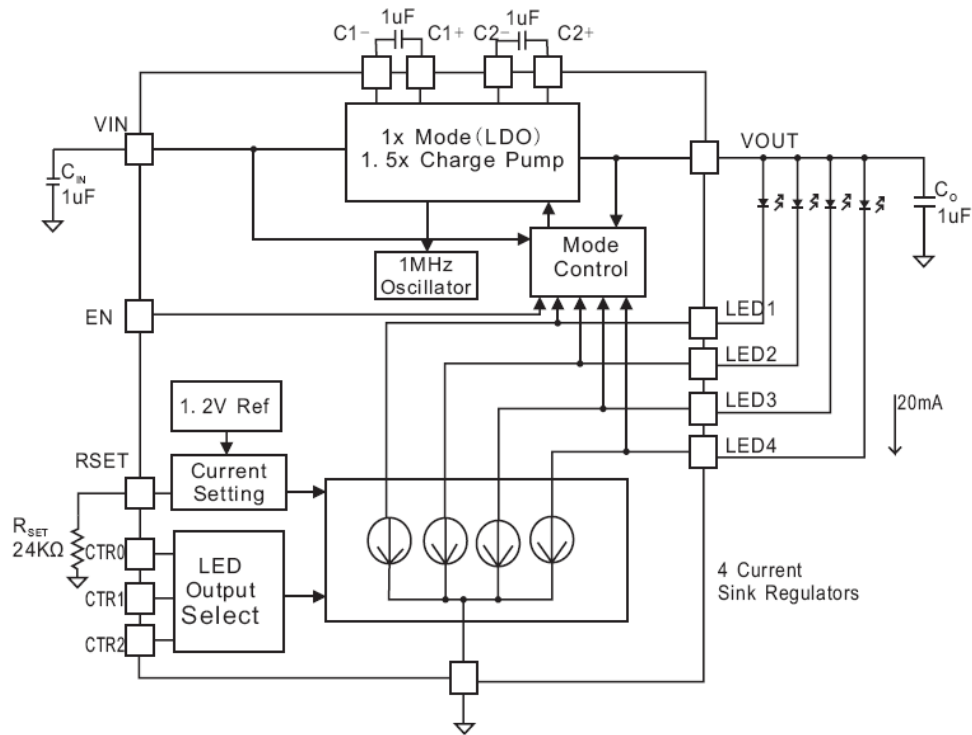

Control Lines			LED Output			
CTR2	CTR1	CTR0	LED4	LED3	LED2	LED1
0	0	0	-	-	-	ON
0	0	1	-	-	ON	-
0	1	0	-	ON	-	-
0	1	1	ON	-	-	-
1	0	0	-	-	ON	ON
1	0	1	-	ON	ON	ON
1	1	0	ON	ON	ON	ON
1	1	1	-	-	-	-

1 = Logic high (or V_{IN}), 0 = Logic low (or GND), - = LED output off

Table 1: LED Enable Logic

PIN DESCRIPTION

Thin QFN-16 3mmx3mm

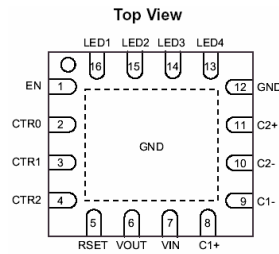

Pin Number	Name	Description
1	EN	Enable Input, Active High
2	CTR0	Digital Control Input 0
3	CTR1	Digital Control Input 1
4	CTR2	Digital Control Input 2
5	RSET	Set Resistance
6	VOUT	Charge pump output connected to the LED anodes
7	VIN	Supply Voltage
8	C1+	Bucket Capacitor 1 Terminal
9	C1-	Bucket Capacitor 1 Terminal
10	C2-	Bucket Capacitor 2 Terminal
11	C2+	Bucket Capacitor 2 Terminal
12	GND	Ground Reference
13	LED4	LED4 Cathode Terminal
14	LED3	LED3 Cathode Terminal
15	LED2	LED2 Cathode Terminal
16	LED1	LED1 Cathode Terminal

ELECTRICAL SPECIFICATIONS

Absolute Maximum Ratings

These are stress ratings only and functional operation is not implied. Exposure to absolute maximum ratings for prolonged time periods may affect device reliability. All voltages are with respect to ground.

V_{IN} , V_{OUT} , LEDx, Pin Voltage.....	-0.3V to 6V	Storage Temperature Range	-65°C to +160°C
EN, CTRx Pin Voltage	-0.3V to V_{IN}	Lead Temperature	300°C
RSET Pin Voltage	-0.3V to V_{IN}	ESD Ratings – Human Body Model.....	2000V
Ambient Temperature Range	-40°C to +85°C		

Recommended Operating Conditions

V_{in}	+2.7V to +5.5V	Ambient Temperature	-40°C to +85°C
Input/Output/Bucket Capacitors...	$1 \pm 20\% \mu\text{F}$ (typ)	ILED per LED	0mA to 30mA

Thermal Information

Parameter	Symbol	Package	Max	Unit
Thermal Resistance (Junction to Ambient)	θ_{JA}	TQFN-16	34	°C
Power Dissipation P_D @ $T_A = 25^\circ\text{C}$	P_D	TQFN-16	2.9	W

ELECTRICAL SPECIFICATIONS

$T_A=25^{\circ}\text{C}$, $V_{\text{IN}}=3.5\text{V}$, $C_{\text{IN}}=C_{\text{OUT}}=1\mu\text{F}$, unless otherwise noted.

Parameter	Symbol	Conditions	Min	Typ.	Max	Unit
Input Voltage Range	V_{IN}		2.7		5.5	V
Shutdown Current	I_{SD}	VEN=0V Shutdown Mode		0.05	1	μA
Quiescent Current	I_{Q}	1X Mode, No Load		0.6	1.2	mA
		1.5x Mode, No Load		2.5	5	mA
RSET Regulated Voltage	V_{RSET}		1.19	1.23	1.25	V
Programmed LED Current	I_{LED}	$R_{\text{SET}}=90\text{k}\Omega$ $R_{\text{SET}}=29.3\text{k}\Omega$ $R_{\text{SET}}=14.7\text{k}\Omega$		5.0 15.0 30.0		mA
LED Current Accuracy	$I_{\text{LED-ACC}}$			± 5		%
LED Channel Matching	$I_{\text{LED-DEV}}$	$(I_{\text{LED}}-I_{\text{LEDAVG}})/I_{\text{LEDAVG}}$		± 3		%
Output Resistance (Open Loop)	R_{O}	1x Mode, $I_{\text{O}}=100\text{mA}$ 1.5x Mode, $I_{\text{O}}=100\text{mA}$		1.7 4.3		Ω
Charge Pump Frequency	f_{OSC}			1.0		MHz
VIN at Mode Transition from 1x to 1.5x	$V_{\text{IN-TRAN}}$	$I_{\text{LED}}=15\text{mA}$ $I_{\text{LED}}=20\text{mA}$		3.45 3.60		V
1x to 1.5x Mode Transition Dropout Delay	T_{DROP}		0.4	0.6	0.9	ms
Input Leakage Current	$I_{\text{EN-CTR}}$	On Inputs EN, CTR0, 1 & 2			1	μA
High Detect Threshold	$I_{\text{EN-CTRH}}$	On Inputs EN, CTR0, 1 & 2	1.5			V
Low Detect Threshold	$I_{\text{EN-CTRL}}$	On Inputs EN, CTR0, 1 & 2			0.4	V

Typical Characteristics

$V_{\text{IN}}=3.6\text{V}$, $\text{EN}=V_{\text{IN}}$, $R_{\text{SET}}=24\text{k}\Omega$, $C_{\text{IN}}=1\mu\text{F}$, $T_A=25^{\circ}\text{C}$, unless otherwise noted.

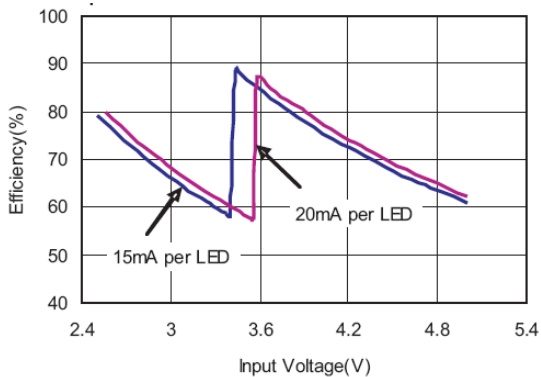

1. Efficiency vs Input Voltage (4 LEDs)

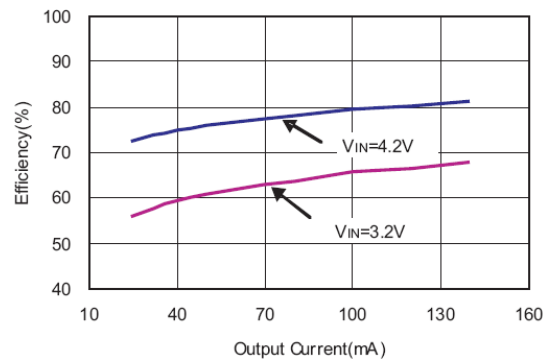

2. Efficiency vs Output Current (4 LEDs)

ELECTRICAL SPECIFICATIONS

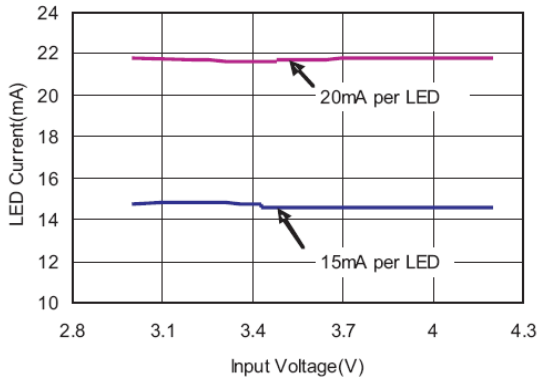

3. LED Current vs Input Voltage (4 LEDs)

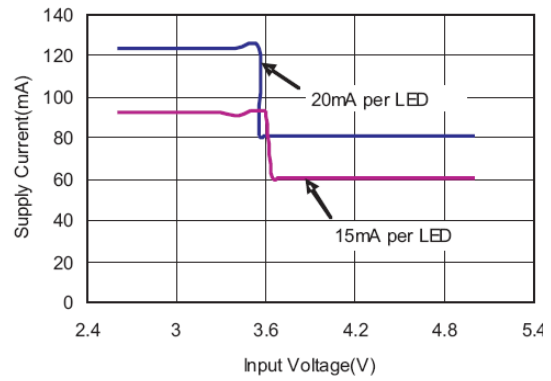

4. Supply Current vs Input Voltage (4 LEDs)

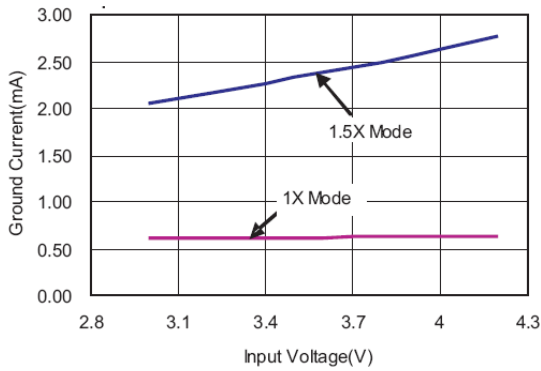

5. Ground Current vs Input Voltage

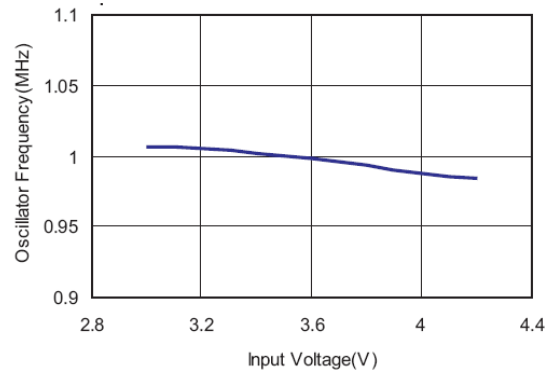

6. Oscillator Frequency vs Input Voltage

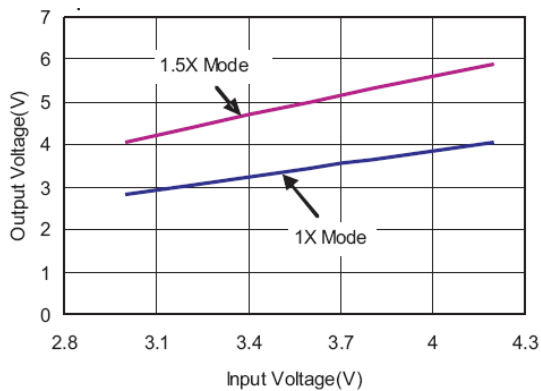

7. Output Voltage vs Input Voltage

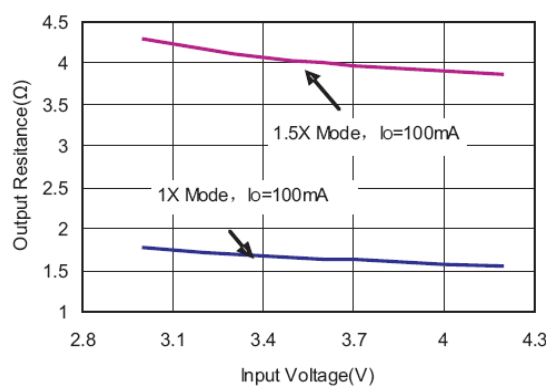

8. Output Resistance vs Input Voltage

ELECTRICAL SPECIFICATIONS

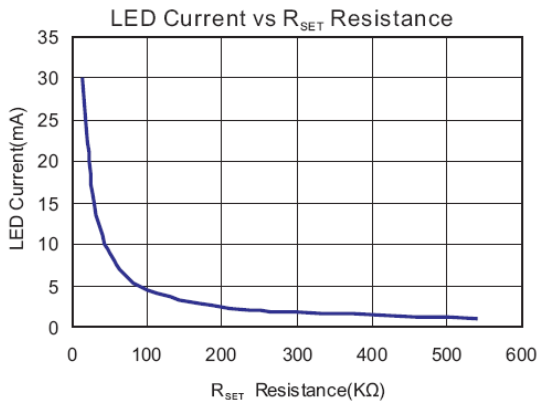

9. LED Current Setting Using RSET

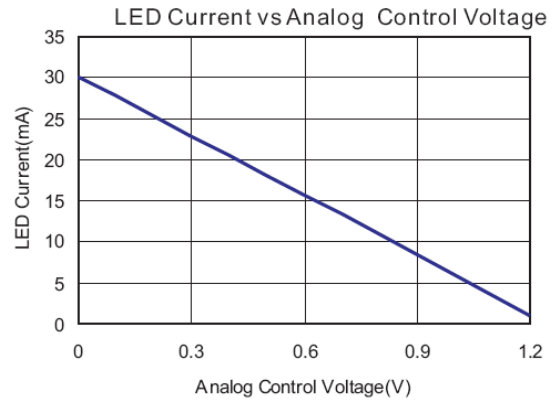

10. LED Current Setting Using a DC Voltage to RSET Pin

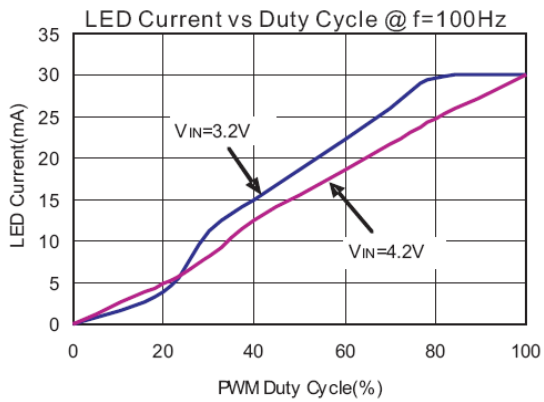

11. LED Current Setting Using a PWM Signal to EN Pin

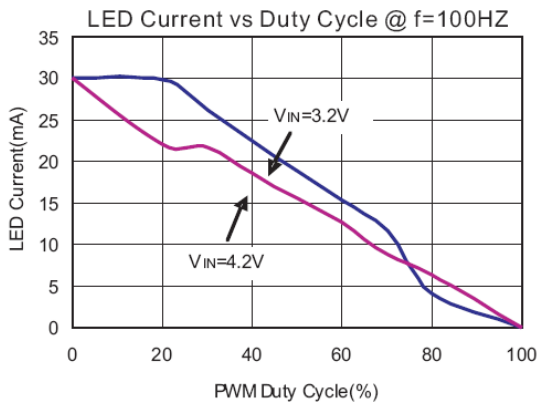
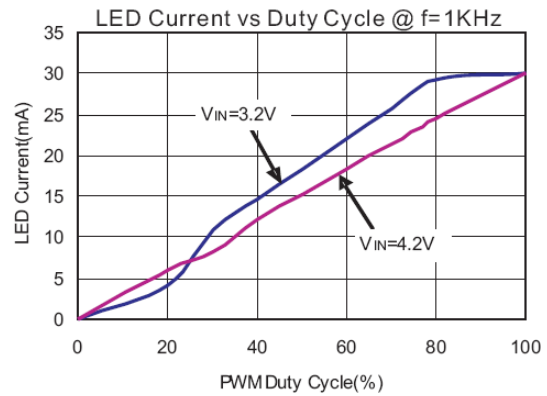

12. LED Current Setting Using a PWM Signal to CTR0 Pin

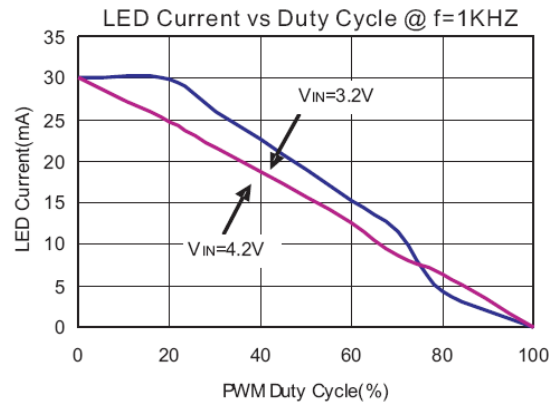

ELECTRICAL SPECIFICATIONS

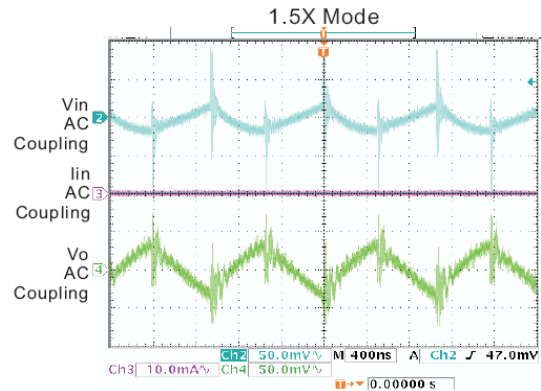
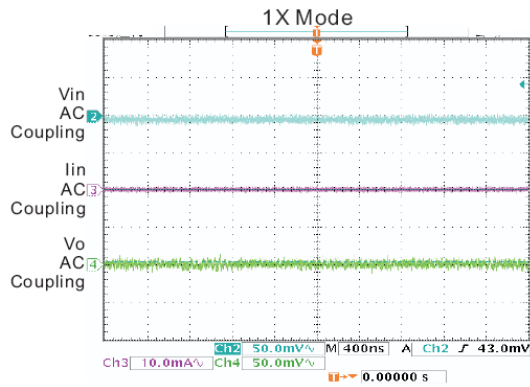

13. Output Ripple

THEORY OF OPERATION

Detailed Description

As shown in the block diagram on page 2, the main components within the SP6887 include a fractional charge pump, mode selection circuit, output selection logic, LED current setting detection circuit, and 4 current sense circuits.

The fractional charge pump multiplies the input voltage a multiple of 1X and 1.5X times the input voltage. The charge pump switches at a fixed 1MHz when the mode is 1.5X. The charge pump does not switch during 1X mode, saving power and improving efficiency.

The mode selection circuit automatically selects the mode as 1X or 1.5X based on circuit conditions such as LED voltage, input voltage and load current. 1X is the more efficient mode than 1.5X mode.

Table 1 on page 2 shows the output selection logic control over the LED outputs for on and off functions with 8 different output states.

The current set and detection circuit uses an external resistor and a 1.20V reference to program the LED current.

4 current regulating circuits sink matched currents from the LEDs. LEDs with matched forward voltage will produce the best possible matched currents. For best

matching performance it is recommended that the V_f between LEDs be under 250mV.

The unused LED channels can be turned off by CTR0, CTR1 and CTR2, and connecting the respective LED pins to VOUT pin, in which case, the corresponding LED driver sink current is only about 20 μ A.

Methods for Setting LED Current

There are 4 methods for setting and adjusting the LED current outlined here.

The methods are:

- 1) RSET only
- 2) Analog Reference VSET
- 3) PWM Input at CTR0
- 4) PWM Input at EN

Method 1: LED Current Setting Using the External Resistor RSET

The most basic means of setting the LED current is with a resistor connected from RSET to GND, as shown in the application circuit on Page 1.

The resistor RSET establishes the reference current needed for a constant LED current. Values of RSET for a fixed LED current are given in Table 2, "RSET

THEORY OF OPERATION

Resistor Selection". Method 2 is for setting the LED current while allowing for brightness control.

I _{LED} (mA)	R _{SET} (kΩ)	Standard Value (kΩ)	Value % Difference
30	14.7	14.7	0.0%
20	21.8	22.0	0.9%
15	29.3	29.4	0.3%
10	44.1	44.2	0.2%
9	49.4	49.9	1.0%
8	55.7	56.0	0.5%
7	64.2	63.4	0.3%
6	75.0	75.0	0.0%
5	90.0	88.7	-0.3%
4	114.2	115.0	0.7%
3	156.5	158.0	0.9%
2	238.0	237.0	-0.4%
1	540.0	536.0	-0.7%

Table 2: R_{SET} Resistor Selection

Method 2: LED Current Setting Using a DC Voltage to RSET Pin

The example circuit in Figure 1 uses a 14.7k resistor and an analog input DC voltage, V_{SET}, which varies from 1.2V to 0V to control LED current from 1mA to 30mA. Table 3 shows the resulting output. If necessary, the analog V_{SET} voltage can be sourced from a voltage higher than 1.20V, but the source must be divided down so that the V mode will not exceed 1.20V. For lower current applications and for higher resolution, a larger resistor may be substituted in this circuit. PWM applications are also possible with this circuit by application of RC filtering.

V _{SET} (V)	I _{LED} (mA)	V _{SET} (V)	I _{LED} (mA)
0.0	30.0	0.7	13.3
0.1	27.7	0.8	10.9
0.2	25.3	0.9	8.4
0.3	22.9	1.0	6.0
0.4	20.5	1.1	3.6
0.5	18.1	1.2	1.1
0.6	15.7		

Table 3: Analog Voltage for LED Current Control

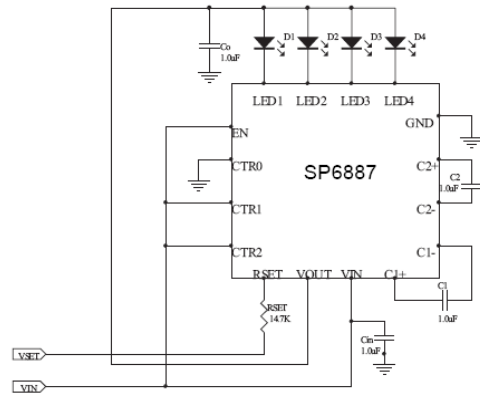

Figure 1: Analog Voltage for LED Current Control

Method 3: LED Current Setting Using a PWM Signal to CTRx Pin

The circuit in Figure 2 turns 4 LEDs on and off by a PWM signal to the CTR0. This circuit uses resistor RSET to set the on state current and the average LED current is, then proportional to the percentage of on-time when the CTR0 pin is logic low. Average LED current is approximately equal to:

$$I_{LED\text{AVG}} = (t_{ON} * I_{LED_ON}) / (t_{ON} + t_{OFF})$$

The recommended PWM frequency is between 100Hz and 1KHz. Due to start up delay and ramp up time, frequency >1KHz will result in error in the average value of I_{LED}. Frequency <100Hz can naturally cause the LEDs to blink visibly.

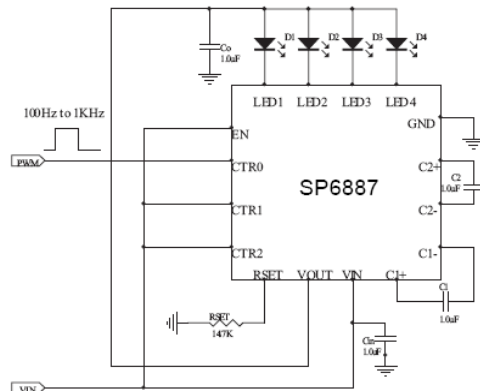

Figure 2: PWM Signal at CTR0 Pin for LED Current Control

Method 4: LED Current Setting Using a PWM Signal to EN Pin

The 4 LEDs turn on and off by applying a PWM signal to the EN pin as shown in figure 3. The circuit is the same as to the method 3, using a resistor RSET to set the on state current and the average LED current is then proportional to the percentage of on-time when the EN pin is logic low. Average LED current is approximately equal to:

$$I_{LED_{AVG}} = (t_{ON} * I_{LED_{ON}}) / (t_{ON} + t_{OFF})$$

Similarly, the recommended PWM frequency is between 100Hz and 1KHz. Due to start up delay and ramp up time, frequency >1KHz will result in error in the average value of ILED. Frequency <100Hz can naturally cause the LEDs to blink visibly.

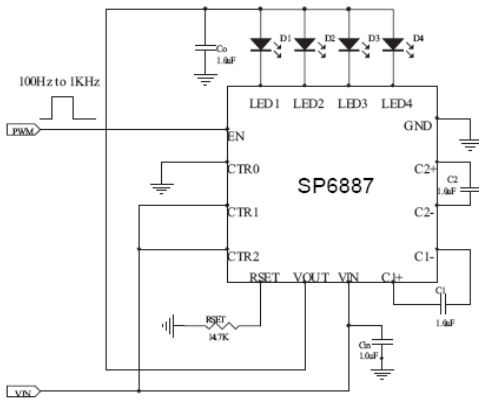

Figure 3: PWM Signal at EN Pin for LED Current Control

PCB Layout

When the driver is in the 1.5X charge pump mode, the 1MHz switching frequency operation require to minimize the trace length and impedance to ground on all 4 capacitors. A ground plane should cover the area on the bottom side of the PCB opposite to the IC and the bypass capacitors. Capacitors CIN and Co require to short connection to ground which can be done with multiple vias as shown on Figure4.

Square copper area matches the QFN 16 exposed pad (GND) which is connected by a trace to the pin 12 pad (GND). A large via (metalized hole) centered in the square pad provides a low impedance connection to the ground plane on the opposite side of the PCB and allows the heat dissipated by the driver IC to spread out resulting in excellent thermal performance.

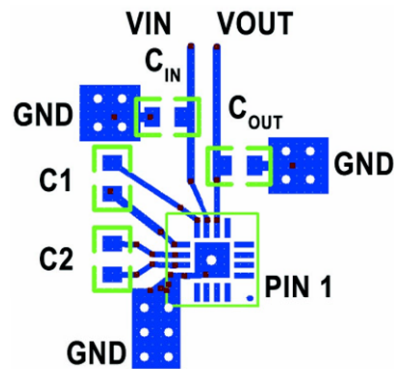
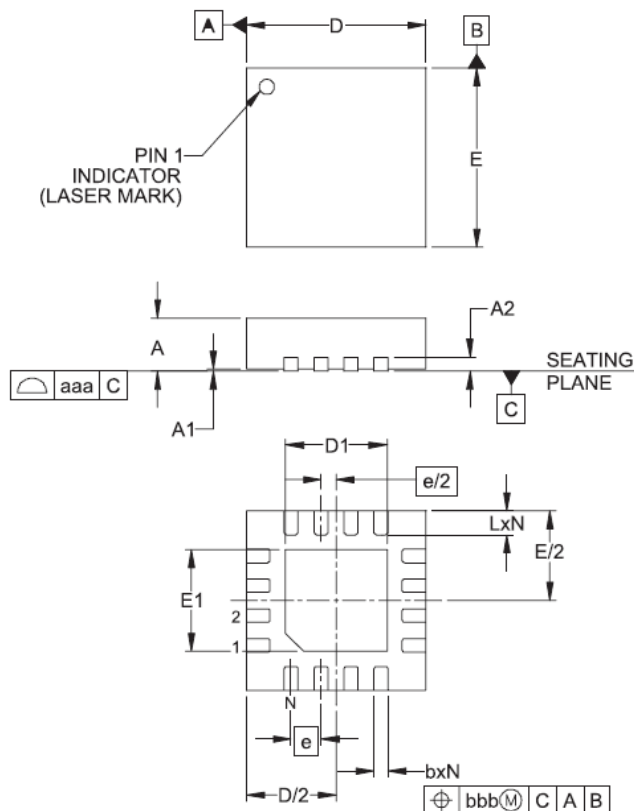

Figure 4: PCB Lay-out

Thin QFN-16 3mm x 3mm

Units: mm (angles in degrees)
 Coplanarity applies to the exposed pads as well as terminals
 DAP is 1.90mm x 1.90mm



DIMENSIONS (mm)			
	MIN	TYP	MAX
A	0.70	0.75	0.80
A1	0.00	0.02	0.05
A2	0.20		
b	0.18	0.25	0.30
D	2.90	3.00	3.10
D1	1.55	1.70	1.80
E	2.90	3.00	3.10
E1	1.55	1.70	1.80
e	0.50BSC		
L	0.30	0.40	0.50
N	16		
aaa	0.08		
bbb	0.10		

ORDERING INFORMATION

Part Number	Operating Temperature Range	Package	Marking	Packing Quantity
SP6887ER4-L	-40°C to +85°C	Thin QFN-16	6887 ER4 YWWX	-
SP6887ER4-L/TR	-40°C to +85°C	Thin QFN-16	6887 ER4 YWWX	3,000/T&R

"Y" = Year, "WW" = Work Week, "X" = first alpha of lot number



**Exar Corporation
 Headquarters and Sales Offices**

48720 Kato Road
 Fremont, CA 94538 – USA
 Tel.: +1 (510) 668-7000
 Fax: +1 (510) 668-7030
 www.exar.com