

## Low-Power 3.3V-Supply Full-Duplex RS-485 Driver/Receiver

Check for Samples: [SN65HVD37](#)

### FEATURES

- **Low-Current Standby Mode:** <1  $\mu$ A Typical
- **Operational Quiescent Current** < 1 mA
- **High Receiver Hysteresis for Noise Immunity (60 mV Typical)**
- **1/8 Unit-Load (Up to 256 Nodes on the Bus)**
- **Bus-pin ESD Protection Exceeds 15 kV HBM**
- **Driver Output Transition Times Optimized for Signaling Rate up to 20 Mbps**
- **Glitch-Free Power-Up and Power-Down Protection for Hot-Plugging Applications**
- **5V-Tolerant Logic Inputs**
- **Bus Idle, Open, and Short-Circuit Failsafe**
- **Driver Current Limiting and Thermal Shutdown**
- **Fully Meets All TIA-485-A Specifications**

### APPLICATIONS

- **Telecommunications Equipment**
- **Industrial Automation**
- **Process Automation**
- **Building Automation**
- **Point-of-Sale (POS) Terminals**
- **Improved Replacement for ADM3076, ADM3491, LTC2852, MAX3491 and SP3491**

### DESCRIPTION

The SN65HVD37 combines a robust differential driver and a receiver with high noise immunity for demanding industrial applications. The driver differential outputs and the receiver differential inputs are separate pins, to form a bus port for full-duplex (four-wire) communications. The driver and receiver can be independently enabled, and feature a wide common-mode voltage range, making this device suitable for multi-point applications over long cable runs. The SN65HVD37 is characterized over the temperature range of -40°C to 85 °C.

#### D PACKAGE (TOP VIEW)

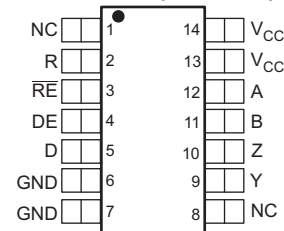

NC - No internal connection

#### LOGIC DIAGRAM (POSITIVE LOGIC)

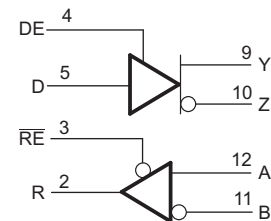

Figure 1. 60 mV Receiver Hysteresis for Noise Immunity



Please be aware that an important notice concerning availability, standard warranty, and use in critical applications of Texas Instruments semiconductor products and disclaimers thereto appears at the end of this data sheet.



These devices have limited built-in ESD protection. The leads should be shorted together or the device placed in conductive foam during storage or handling to prevent electrostatic damage to the MOS gates.

## ABSOLUTE MAXIMUM RATINGS<sup>(1)</sup>

		VALUE/UNITS
$V_{CC}$	Supply voltage	–0.5 V to 7 V
	Voltage range at A, B, Y, Z pins	–13 V to 13 V
	Input voltage range at any logic pin	–0.3 V to 5.7 V
	Voltage range, transient pulse, A, B, Y, Z, through 100 $\Omega$	–25 V to 25 V
	Receiver output current	–24 mA to 24 mA
$T_J$	Junction temperature	170°C
	Continuous total power dissipation	(see Thermal Table)
IEC 60749-26 ESD	(Human Body Model), bus terminals and GND	$\pm 16$ kV
JEDEC Standard 22	Test Method A114 (Human Body Model), all pins	$\pm 5$ kV
	Test Method C101 (Charged Device Model), all pins	$\pm 1.5$ kV
JEDEC Standard 22	Test Method A115 (Machine Model), all pins	$\pm 150$ V

- (1) Stresses beyond those listed under "absolute maximum ratings" may cause permanent damage to the device. These are stress ratings only and functional operation of the device at these or any other conditions beyond those indicated under "recommended operating conditions" is not implied. Exposure to absolute-maximum-rated conditions for extended periods may affect device reliability.

## THERMAL INFORMATION

THERMAL METRIC <sup>(1)</sup>		SN65HVD37	UNITS
		D	
		14 PINS	
$\theta_{JA}$	Junction-to-ambient thermal resistance	79.3	°C/W
$\theta_{JCTop}$	Junction-to-case (top) thermal resistance	44.8	
$\theta_{JB}$	Junction-to-board thermal resistance	33.5	
$\Psi_{JT}$	Junction-to-top characterization parameter	13.3	
$\Psi_{JB}$	Junction-to-board characterization parameter	33.3	

- (1) For more information about traditional and new thermal metrics, see the *IC Package Thermal Metrics* application report, [SPRA953](#).

## RECOMMENDED OPERATING CONDITIONS

		MIN	NOM	MAX	UNIT
$V_{CC}$	Supply voltage <sup>(1)</sup>	3	3.3	3.6	V
$V_I$	Input voltage at any bus terminal (separately or common mode) <sup>(2)</sup>	–7		12	V
$V_{IH}$	High-level input voltage (Driver, driver enable, and receiver enable inputs)	2		$V_{CC}$	V
$V_{IL}$	Low-level input voltage (Driver, driver enable, and receiver enable inputs)	0		0.8	V
$V_{ID}$	Differential input voltage	–12		12	V
$I_O$	Output current	Driver		60	mA
		Receiver	–8	8	
$R_L$	Differential load resistance	54	60		$\Omega$
$C_L$	Differential load capacitance		50		pF
	Signaling rate		HVD37	20	Mbps
$T_A$	Operating free-air temperature (See application section for thermal information)	–40		85	°C
$T_J$	Junction Temperature	–40		150	°C

- (1) Both pins 13 and 14 should be connected to the supply voltage; both pins 6 and 7 should be connected to ground.  
 (2) The algebraic convention, in which the least positive (most negative) limit is designated as minimum is used in this data sheet.

## ELECTRICAL CHARACTERISTICS

over recommended operating conditions (unless otherwise noted)

PARAMETER		TEST CONDITIONS		MIN	TYP	MAX	UNIT	
V <sub>OD</sub>	Driver differential output voltage magnitude	See Figure 1, R <sub>L</sub> = 60 Ω, V <sub>CC</sub> ≥ 3.15 V, 375 Ω on each output to –7 V to 12 V		1.5	1.9		V	
		R <sub>L</sub> = 54 Ω (RS-485)	See Figure 3	1.5	2		V	
		R <sub>L</sub> = 100 Ω (RS-422), T <sub>J</sub> ≥ 25°C, V <sub>CC</sub> ≥ 3.3 V		2	2.2		V	
Δ V <sub>OD</sub>	Change in magnitude of driver differential output voltage	R <sub>L</sub> = 54 Ω, C <sub>L</sub> = 50 pF		–0.1	0	0.1	V	
V <sub>OC(SS)</sub>	Steady-state common-mode output voltage	Center of two 27-Ω load resistors, C <sub>L</sub> = 50 pF		See Figure 3	1.5	V <sub>CC</sub> /2	2.5	V
ΔV <sub>OC</sub>	Change in differential driver output common-mode voltage				–0.1	0	0.1	V
V <sub>OC(PP)</sub>	Peak-to-peak driver common-mode output voltage					400		mV
C <sub>ID</sub>	Differential input capacitance	A, B			3		pF	
C <sub>OD</sub>	Differential output capacitance	Y, Z			14		pF	
V <sub>IT+</sub>	Positive-going receiver differential input voltage threshold			See <sup>(1)</sup>	–60	–20	mV	
V <sub>IT–</sub>	Negative-going receiver differential input voltage threshold			–200	–120	See <sup>(1)</sup>	mV	
V <sub>HYS</sub>	Receiver differential input voltage threshold hysteresis (V <sub>IT+</sub> – V <sub>IT–</sub> )			30	60		mV	
V <sub>OH</sub>	Receiver high-level output voltage	I <sub>OH</sub> = –8 mA		2.4	V <sub>CC</sub> – 0.3		V	
V <sub>OL</sub>	Receiver low-level output voltage	I <sub>OL</sub> = 8 mA			0.2	0.4	V	
I <sub>I</sub>	Driver input, driver enable, and receiver enable input current			–2		2	μA	
I <sub>OZ</sub>	Receiver output high-impedance current	V <sub>O</sub> = 0 V or V <sub>CC</sub> , $\overline{RE}$ at V <sub>CC</sub>		–1		1	μA	
I <sub>OS</sub>	Driver short-circuit output current			–250		250	mA	
I <sub>I</sub>	Bus input current (disabled driver)	V <sub>CC</sub> = 3 to 3.6 V or V <sub>CC</sub> = 0 V, DE at 0 V		V <sub>I</sub> = 12 V		75	125	μA
				V <sub>I</sub> = –7 V		–100	–40	
I <sub>CC</sub>	Supply current, steady-state, no load (quiescent)	Driver and Receiver enabled	DE = V <sub>CC</sub> , RE = GND		720	850	μA	
		Driver enabled, receiver disabled	DE = V <sub>CC</sub> , RE = V <sub>CC</sub>			400	μA	
		Driver disabled, receiver enabled	DE = GND, RE = GND			800	μA	
		Driver and receiver disabled (standby)	DE = GND, D = open, RE = V <sub>CC</sub>	0.2	1	μA		
Supply current (dynamic)		See "TYPICAL CHARACTERISTICS" section						

 (1) Under any specific conditions, V<sub>IT+</sub> is assured to be at least V<sub>HYS</sub> higher than V<sub>IT–</sub>.

## SWITCHING CHARACTERISTICS

over recommended operating conditions (unless otherwise noted)

PARAMETER		TEST CONDITIONS	MIN	TYP	MAX	UNIT	
<b>DRIVER</b>							
$t_r, t_f$	Driver differential output rise/fall time	$R_L = 54 \Omega, C_L = 50 \text{ pF}$ , See <a href="#">Figure 4</a>	3	6	14	ns	
$t_{PHL}, t_{PLH}$	Driver propagation delay		10		20		
$t_{SK(P)}$	Driver pulse skew, $ t_{PHL} - t_{PLH} $				1		
$t_{PHZ}, t_{PLZ}$	Driver disable time	See <a href="#">Figure 5</a> and <a href="#">Figure 6</a>	20		50	ns	
$t_{PZH}, t_{PZL}$	Driver enable time	Receiver enabled	8		25	ns	
		Receiver disabled	2.6		8	$\mu\text{s}$	
<b>RECEIVER</b>							
$t_r, t_f$	Receiver output rise/fall time	$C_L = 15 \text{ pF}$ , See <a href="#">Figure 7</a>	2	5	9	ns	
$t_{PHL}, t_{PLH}$	Receiver propagation delay time		40		50	75	ns
$t_{SK(P)}$	Receiver pulse skew, $ t_{PHL} - t_{PLH} $				2	5	ns
$t_{PLZ}, t_{PHZ}$	Receiver disable time		15		25	ns	
$t_{PZL(1)}, t_{PZH(1)}, t_{PZL(2)}, t_{PZH(2)}$	Receiver enable time	Driver enabled, See <a href="#">Figure 8</a>	35		50	ns	
		Driver disabled, See <a href="#">Figure 8</a>	3		8	$\mu\text{s}$	

### DRIVER FUNCTION TABLE

INPUT	ENABLE	OUTPUTS		
		Y	Z	
H	H	H	L	Actively drive bus High
L	H	L	H	Actively drive bus Low
X	L	Z	Z	Driver disabled
X	OPEN	Z	Z	Driver disabled by default
OPEN	H	H	L	Actively drive bus High by default

### RECEIVER FUNCTION TABLE

DIFFERENTIAL INPUT	ENABLE	OUTPUT	
$V_{ID} = V_A - V_B$	RE	R	
$V_{IT+} < V_{ID}$	L	H	Receive valid bus High
$V_{IT-} < V_{ID} < V_{IT+}$	L	?	Indeterminate bus state
$V_{ID} < V_{IT-}$	L	L	Receive valid bus Low
X	H	Z	Receiver disabled
X	OPEN	Z	Receiver disabled by default
Open-circuit bus	L	H	Fail-safe high output
Short-circuit bus	L	H	Fail-safe high output
Idle (terminated) bus	L	H	Fail-safe high output

EQUIVALENT INPUT AND OUTPUT SCHEMATIC DIAGRAMS

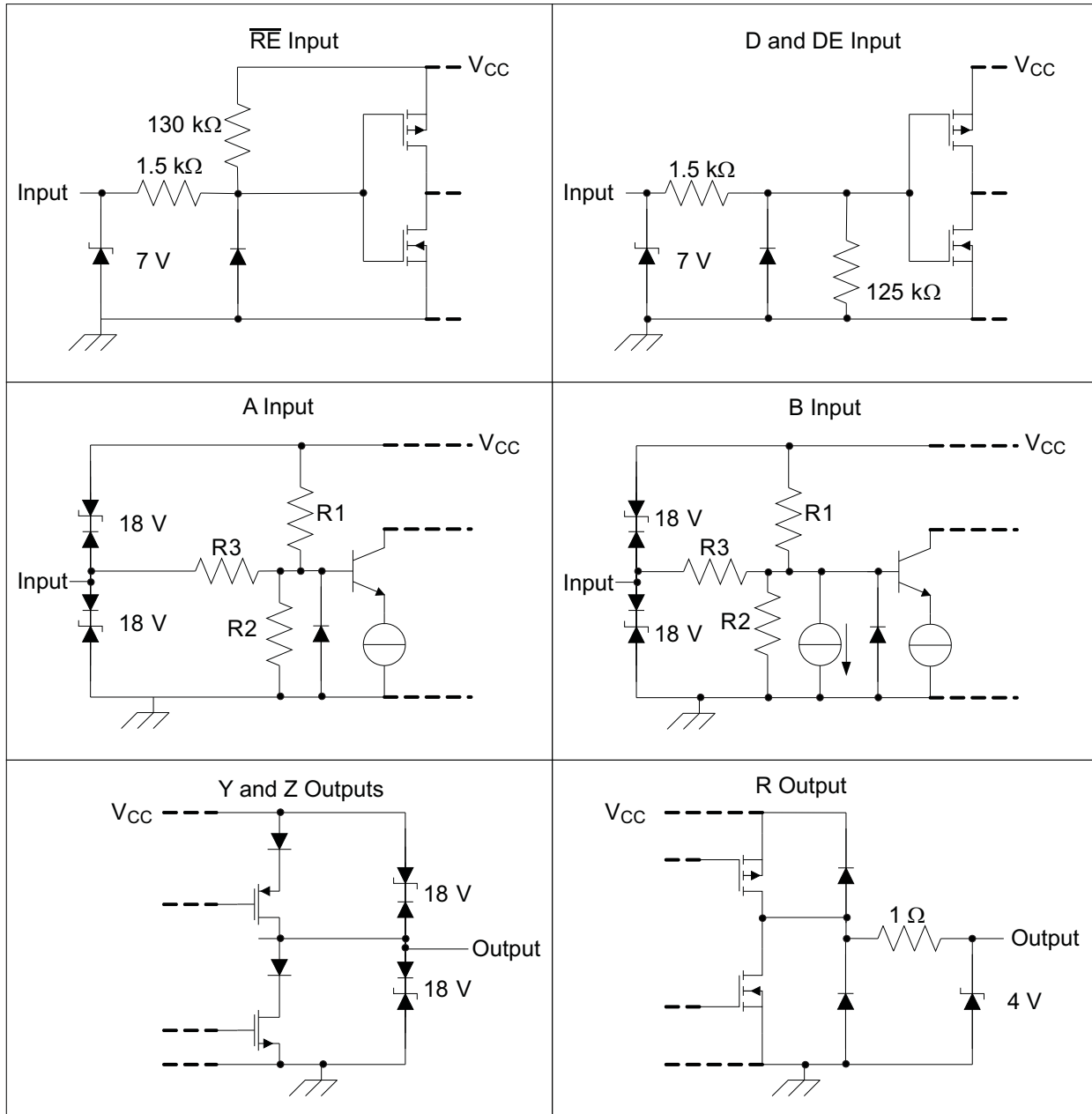

	R1/R2	R3
SN65HVD37	18 kΩ	190 kΩ

**PARAMETER MEASUREMENT INFORMATION**

Input generator rate is 100 kbps, 50% duty cycle, rise and fall times less than 6 nsec, output impedance 50 Ω

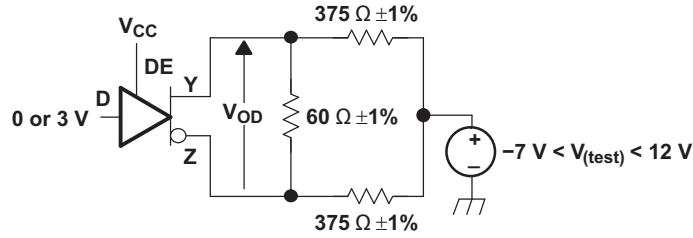

**Figure 2. Measurement of Driver Differential Output Voltage With Common-mode Load**

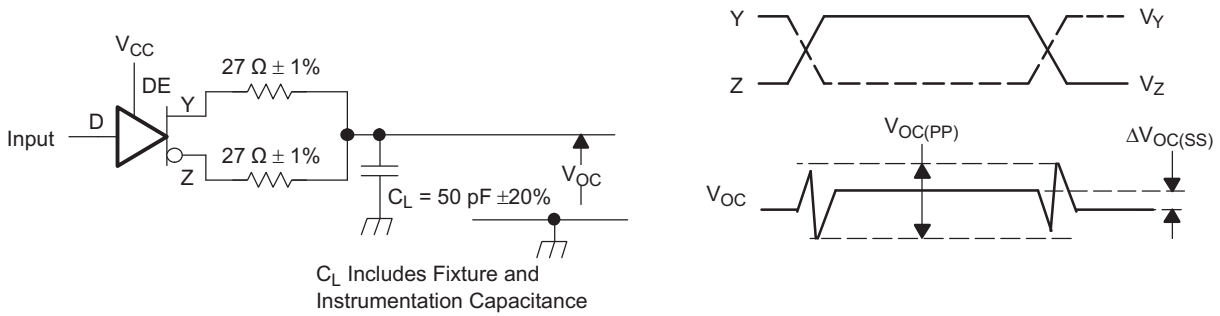

**Figure 3. Measurement of Driver Differential and Common-mode Output with RS-485 Load**

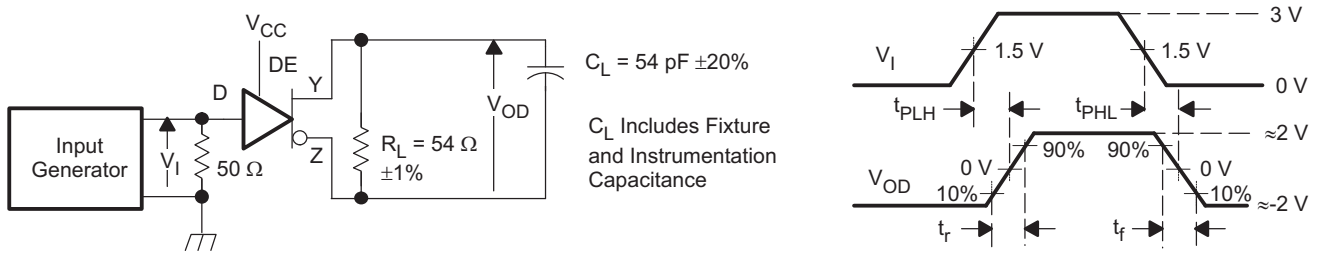

**Figure 4. Measurement of Driver Differential Output Rise and Fall Times and Propagation Delays**

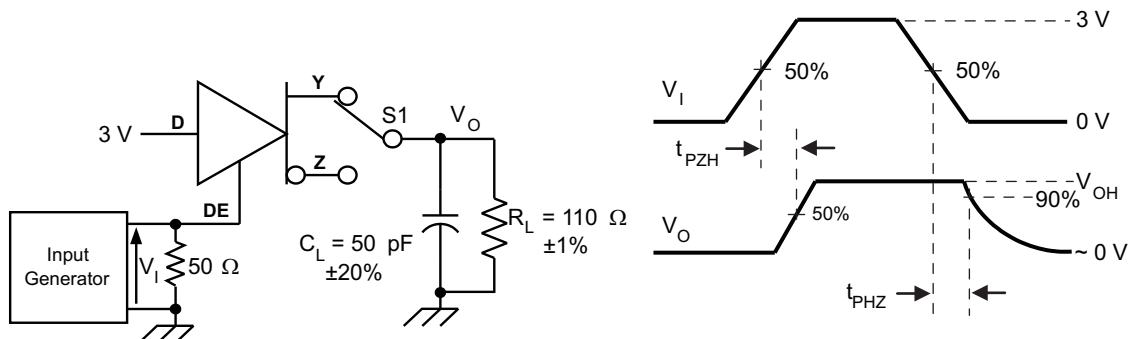

NOTE: D at 3 V to test non-inverting output, D at 0 V to test inverting output.  
 C<sub>L</sub> includes Fixture and Instrumentation Capacitance

**Figure 5. Measurement of Driver Enable and Disable Times with Active High Output and Pull-down Load**

PARAMETER MEASUREMENT INFORMATION (continued)

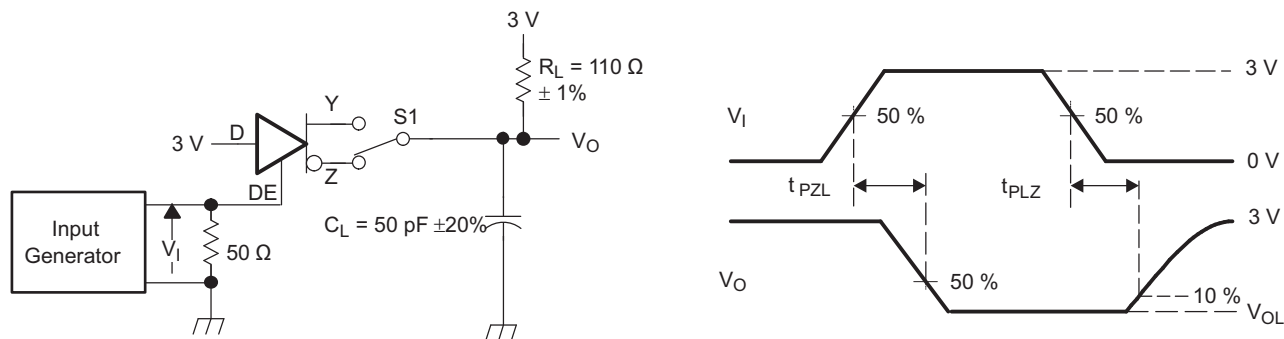

NOTE: D at 0 V to test non-inverting output, D at 3 V to test inverting output.

CL Includes Fixture and Instrumentation Capacitance

Figure 6. Measurement of Driver Enable and Disable Times with Active Low Output and Pull-up Load

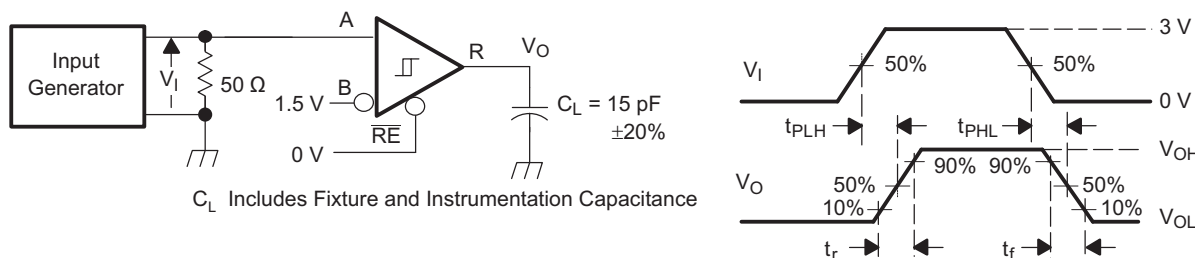

CL Includes Fixture and Instrumentation Capacitance

Figure 7. Measurement of Receiver Output Rise and Fall Times and Propagation Delays

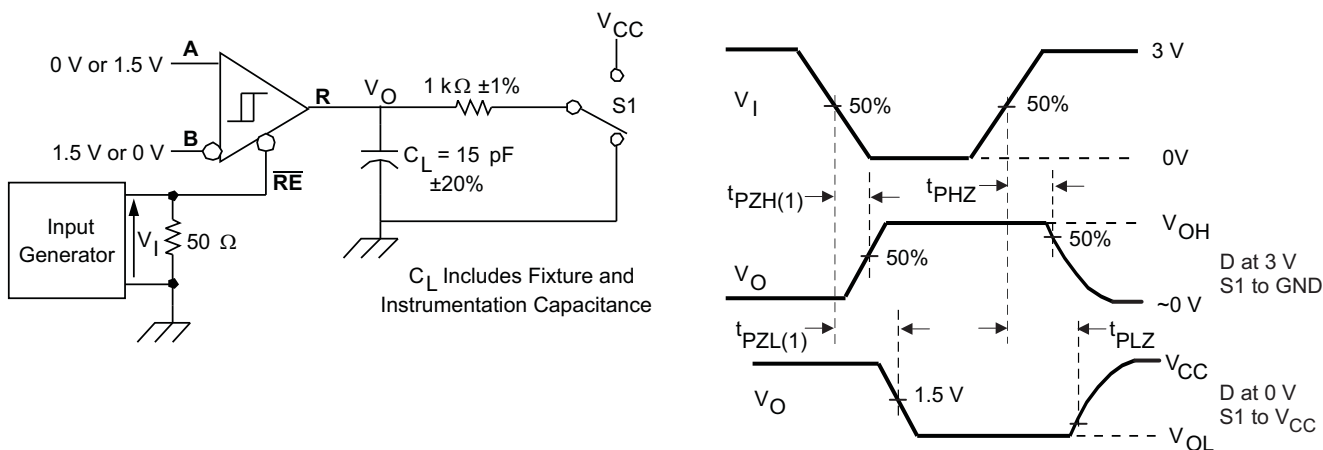

Figure 8. Measurement of Receiver Enable/Disable Times

TYPICAL CHARACTERISTICS

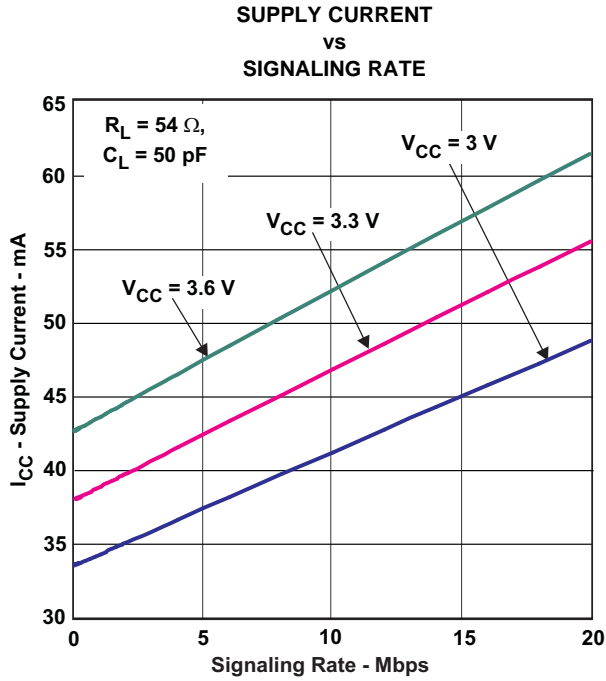

Figure 9.

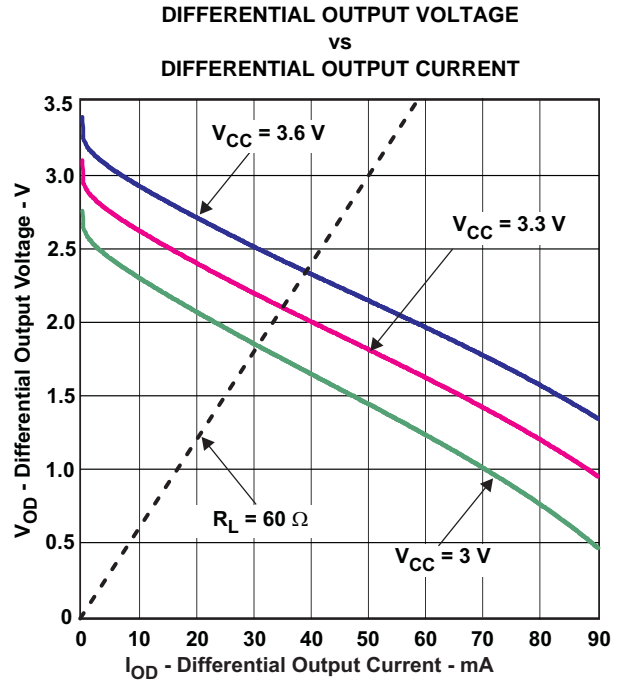

Figure 10.

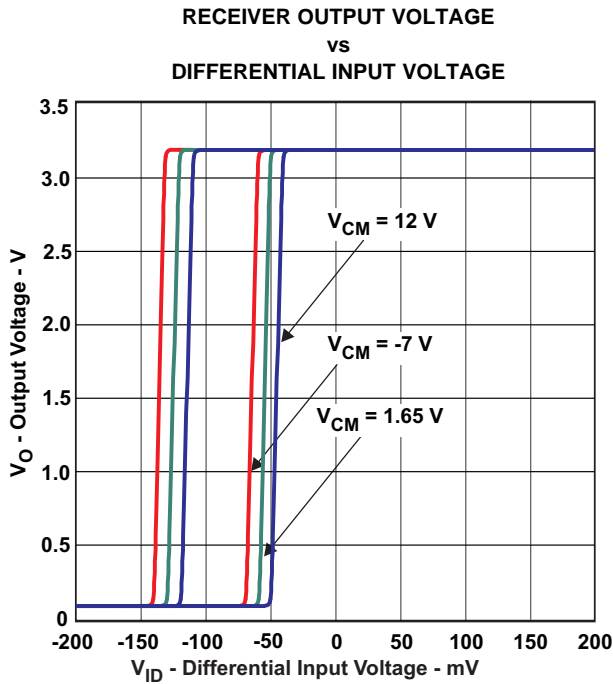

Figure 11.

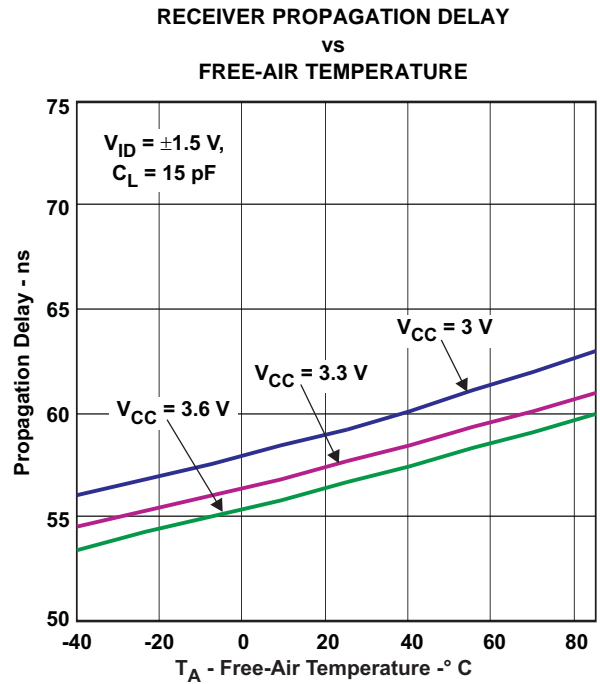

Figure 12.



**TYPICAL CHARACTERISTICS (continued)**

DRIVER RISE/FALL TIME  
vs  
FREE-AIR TEMPERATURE

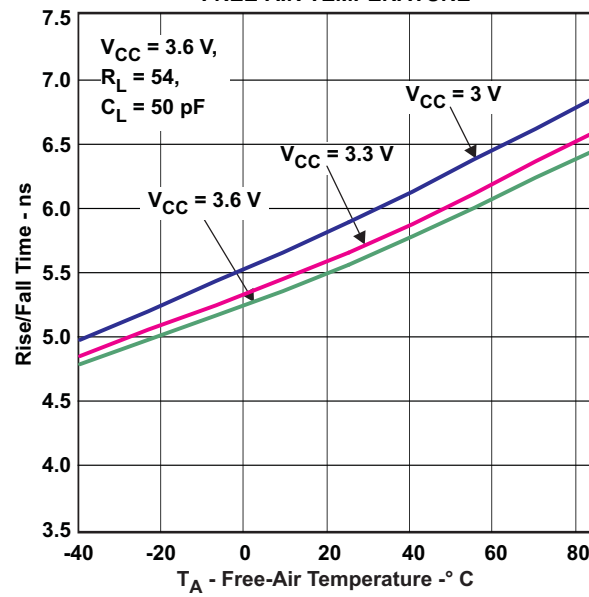

Figure 13.

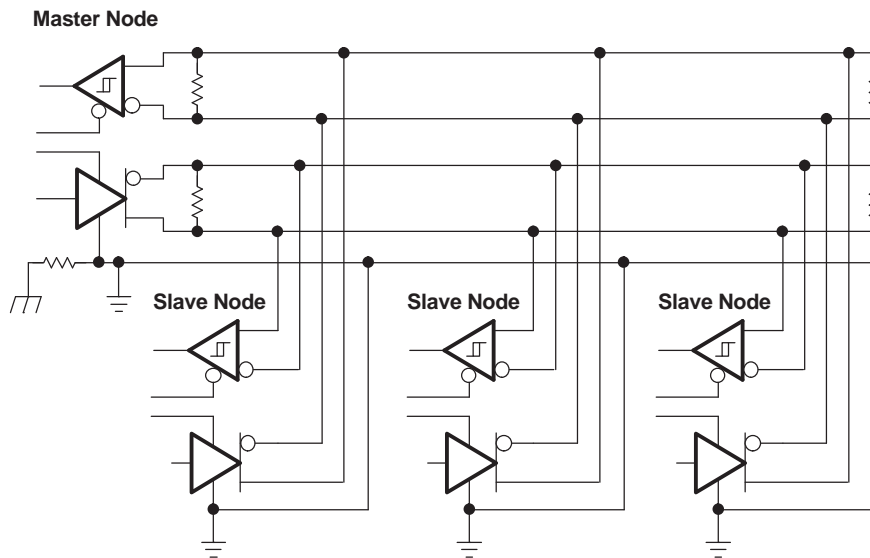

Figure 14. Example Full-Duplex Master/Slave Application Circuit

## APPLICATION INFORMATION

### RECEIVER FAILSAFE

The differential receiver is “failsafe” to invalid bus states caused by:

- open bus conditions such as a disconnected connector,
- shorted bus conditions such as cable damage shorting the twisted-pair together,
- or idle bus conditions that occur when no driver on the bus is actively driving.

In any of these cases, the differential receiver outputs a failsafe logic High state, so that the output of the receiver is not indeterminate.

In the HVD37, receiver failsafe is accomplished by offsetting the receiver thresholds so that the “input indeterminate” range does not include zero volts differential. In order to comply with the RS-422 and RS-485 standards, the receiver output must output a High when the differential input  $V_{ID}$  is more positive than 200 mV, and must output a Low when the  $V_{ID}$  is more negative than -200 mV. The receiver parameters which determine the failsafe performance are  $V_{IT+}$  and  $V_{IT-}$  and  $V_{HYS}$ . In the Electrical Characteristics table,  $V_{IT-}$  has a typical value of -120 mV and a minimum (most negative) value of -200 mV, so differential signals more negative than -200 mV will always cause a Low receiver output. Similarly, differential signals more positive than 200 mV will always cause a High receiver output, because the typical value of  $V_{IT+}$  is -60mV, and  $V_{IT+}$  is never more positive than -20 mV under any conditions of temperature, supply voltage, or common-mode offset.

When the differential input signal is close to zero, it will still be above the  $V_{IT+}$  threshold, and the receiver output will be High. Only when the differential input is more negative than  $V_{IT-}$  will the receiver output transition to a Low state. So, the noise immunity of the receiver inputs during a bus fault condition includes the receiver hysteresis value  $V_{HYS}$  (the separation between  $V_{IT+}$  and  $V_{IT-}$ ) as well as the value of  $V_{IT+}$ .

For the HVD37, the typical noise immunity is about 120 mV, which is the negative noise level needed to exceed the  $V_{IT-}$  threshold ( $V_{IT-}$  TYP = -120 mV). In the worst case, the failsafe noise immunity is never less than 50 mV, which is set by the maximum positive threshold ( $V_{IT+}$  MAX = -20mV) plus the minimum hysteresis voltage ( $V_{HYS}$  MIN = 30 mV).

### HOT-PLUGGING

These devices are designed to operate in “hot swap” or “hot pluggable” applications. Key features for hot-pluggable applications are power-up, power-down glitch free operation, default disabled input/output pins, and receiver failsafe. An internal Power-On Reset circuit keeps the driver outputs in a high-impedance state until the supply voltage has reached a level at which the device will reliably operate. This ensures that no spurious transitions (glitches) will occur on the bus pin outputs as the power supply turns on or turns off.

As shown in the device FUNCTION TABLE, the ENABLE inputs have the feature of default disable on both the driver enable and receiver enable. This ensures that the device will neither drive the bus nor report data on the R pin until the associated controller actively drives the enable pins.

### LOW POWER STANDBY MODE

As is customary with RS-485 devices, the receiver output is directly enabled/disabled by  $\overline{RE}$ , and the driver outputs are directly enabled/disabled by DE.

When both the driver and receiver are disabled, (DE=LO and  $\overline{RE}$ =HI) the receiver differential comparator stage enters a standby mode for reduced power.

When either the Driver or Receiver is enabled, the receiver differential comparator stage is enabled for fast response to signal changes.

---

**REVISION HISTORY**

<b>Changes from Original (October 2011) to Revision A</b>	<b>Page</b>
• Changed the device From: Product Preview To: Production .....	<a href="#">1</a>

---

**PACKAGING INFORMATION**

Orderable Device	Status (1)	Package Type	Package Drawing	Pins	Package Qty	Eco Plan (2)	Lead finish/ Ball material (6)	MSL Peak Temp (3)	Op Temp (°C)	Device Marking (4/5)	Samples
SN65HVD37D	ACTIVE	SOIC	D	14	50	RoHS & Green	NIPDAU	Level-1-260C-UNLIM	-40 to 85	HVD37	<a href="#">Samples</a>
SN65HVD37DR	ACTIVE	SOIC	D	14	2500	RoHS & Green	NIPDAU	Level-1-260C-UNLIM	-40 to 85	HVD37	<a href="#">Samples</a>

(1) The marketing status values are defined as follows:

**ACTIVE:** Product device recommended for new designs.

**LIFEBUY:** TI has announced that the device will be discontinued, and a lifetime-buy period is in effect.

**NRND:** Not recommended for new designs. Device is in production to support existing customers, but TI does not recommend using this part in a new design.

**PREVIEW:** Device has been announced but is not in production. Samples may or may not be available.

**OBSOLETE:** TI has discontinued the production of the device.

(2) **RoHS:** TI defines "RoHS" to mean semiconductor products that are compliant with the current EU RoHS requirements for all 10 RoHS substances, including the requirement that RoHS substance do not exceed 0.1% by weight in homogeneous materials. Where designed to be soldered at high temperatures, "RoHS" products are suitable for use in specified lead-free processes. TI may reference these types of products as "Pb-Free".

**RoHS Exempt:** TI defines "RoHS Exempt" to mean products that contain lead but are compliant with EU RoHS pursuant to a specific EU RoHS exemption.

**Green:** TI defines "Green" to mean the content of Chlorine (Cl) and Bromine (Br) based flame retardants meet JS709B low halogen requirements of <=1000ppm threshold. Antimony trioxide based flame retardants must also meet the <=1000ppm threshold requirement.

(3) MSL, Peak Temp. - The Moisture Sensitivity Level rating according to the JEDEC industry standard classifications, and peak solder temperature.

(4) There may be additional marking, which relates to the logo, the lot trace code information, or the environmental category on the device.

(5) Multiple Device Markings will be inside parentheses. Only one Device Marking contained in parentheses and separated by a "~" will appear on a device. If a line is indented then it is a continuation of the previous line and the two combined represent the entire Device Marking for that device.

(6) Lead finish/Ball material - Orderable Devices may have multiple material finish options. Finish options are separated by a vertical ruled line. Lead finish/Ball material values may wrap to two lines if the finish value exceeds the maximum column width.

**Important Information and Disclaimer:**The information provided on this page represents TI's knowledge and belief as of the date that it is provided. TI bases its knowledge and belief on information provided by third parties, and makes no representation or warranty as to the accuracy of such information. Efforts are underway to better integrate information from third parties. TI has taken and continues to take reasonable steps to provide representative and accurate information but may not have conducted destructive testing or chemical analysis on incoming materials and chemicals. TI and TI suppliers consider certain information to be proprietary, and thus CAS numbers and other limited information may not be available for release.

In no event shall TI's liability arising out of such information exceed the total purchase price of the TI part(s) at issue in this document sold by TI to Customer on an annual basis.



**TAPE AND REEL INFORMATION**

**QUADRANT ASSIGNMENTS FOR PIN 1 ORIENTATION IN TAPE**

\*All dimensions are nominal

Device	Package Type	Package Drawing	Pins	SPQ	Reel Diameter (mm)	Reel Width W1 (mm)	A0 (mm)	B0 (mm)	K0 (mm)	P1 (mm)	W (mm)	Pin1 Quadrant
SN65HVD37DR	SOIC	D	14	2500	330.0	16.4	6.5	9.0	2.1	8.0	16.0	Q1

**TAPE AND REEL BOX DIMENSIONS**

\*All dimensions are nominal

Device	Package Type	Package Drawing	Pins	SPQ	Length (mm)	Width (mm)	Height (mm)
SN65HVD37DR	SOIC	D	14	2500	356.0	356.0	35.0

**TUBE**

\*All dimensions are nominal

Device	Package Name	Package Type	Pins	SPQ	L (mm)	W (mm)	T (μm)	B (mm)
SN65HVD37D	D	SOIC	14	50	506.6	8	3940	4.32



D (R-PDSO-G14)

PLASTIC SMALL OUTLINE



- NOTES:
- A. All linear dimensions are in inches (millimeters).
  - B. This drawing is subject to change without notice.
  -  Body length does not include mold flash, protrusions, or gate burrs. Mold flash, protrusions, or gate burrs shall not exceed 0.006 (0,15) each side.
  -  Body width does not include interlead flash. Interlead flash shall not exceed 0.017 (0,43) each side.
  - E. Reference JEDEC MS-012 variation AB.

## IMPORTANT NOTICE AND DISCLAIMER

TI PROVIDES TECHNICAL AND RELIABILITY DATA (INCLUDING DATA SHEETS), DESIGN RESOURCES (INCLUDING REFERENCE DESIGNS), APPLICATION OR OTHER DESIGN ADVICE, WEB TOOLS, SAFETY INFORMATION, AND OTHER RESOURCES "AS IS" AND WITH ALL FAULTS, AND DISCLAIMS ALL WARRANTIES, EXPRESS AND IMPLIED, INCLUDING WITHOUT LIMITATION ANY IMPLIED WARRANTIES OF MERCHANTABILITY, FITNESS FOR A PARTICULAR PURPOSE OR NON-INFRINGEMENT OF THIRD PARTY INTELLECTUAL PROPERTY RIGHTS.

These resources are intended for skilled developers designing with TI products. You are solely responsible for (1) selecting the appropriate TI products for your application, (2) designing, validating and testing your application, and (3) ensuring your application meets applicable standards, and any other safety, security, regulatory or other requirements.

These resources are subject to change without notice. TI grants you permission to use these resources only for development of an application that uses the TI products described in the resource. Other reproduction and display of these resources is prohibited. No license is granted to any other TI intellectual property right or to any third party intellectual property right. TI disclaims responsibility for, and you will fully indemnify TI and its representatives against, any claims, damages, costs, losses, and liabilities arising out of your use of these resources.

TI's products are provided subject to [TI's Terms of Sale](#) or other applicable terms available either on [ti.com](http://ti.com) or provided in conjunction with such TI products. TI's provision of these resources does not expand or otherwise alter TI's applicable warranties or warranty disclaimers for TI products.

TI objects to and rejects any additional or different terms you may have proposed.

Mailing Address: Texas Instruments, Post Office Box 655303, Dallas, Texas 75265  
Copyright © 2022, Texas Instruments Incorporated